



COMPARATIVE STUDY OF KINESTHETIC PERCEPTIONS OF MALE AND FEMALE FIELD HOCKEY PLAYERS

Pandey Gayatri¹, & Pandey vivek²

¹Research Scholar, Department of Exercise Physiology, L.N.I.P.E. Gwalior, Madhya Pradesh
(India).

²Professor, HOD, Department of Exercise Physiology, L.N.I.P.E., Gwalior, Madhya Pradesh,
(India).

Abstract

The kind of sense organs found within the muscles and joints are called proprioceptors. The function of proprioceptors is conduct sensory reports to the central nervous system from muscles, tendons, ligaments and joints. These sense organs are concerned with kinesthetic senses that, in general, unconsciously tell us where our body part in relation to our environment. Their contributions enable us to execute a smooth and coordinated movement. The purpose of this study was to compare the kinesthetic perception of male and female hockey players. Total 15 male and 15 female intervarsity hockey players of 18 to 24 years old from L.N.I.P.E Gwalior (M.P), were selected as subjects for this study. The kinesthetic perception of the subject was measured with the administration of kinesthetic obstacles test. To determine the difference of kinesthetic perception among male and female hockey players independent t-test test was employed and the significant level was set at 0.05. The result of the data indicated that there was no significant difference between male and female field hockey players.

Key words: Proprioceptors, Kinesthetic Senses, Muscles, Tendons, Ligaments.



[Scholarly Research Journal's](http://www.srjis.com) is licensed Based on a work at www.srjis.com

Introduction: Every human being has an inborn tendency to participate in physical activity. No matter how young one is involved directly or in some or other form of movement. To be a good sportsperson one has to develop various qualities within him. A sportsperson should have good kinesthetic perception ability; stability; speed; strength; suppleness; endurance and skill related to particular sports and game (Singh R.M, 2000).

The capability of sensing the voluntary movement of one's body and the position of its part was first brought to scientific attention early in the 19th century by Sir Charles Bell. He called it the muscle sense; later it was as the sixth sense; and today we refer to it as kinesthetic sensitivity, from Greek root, kinesis meaning "movement"(Fernald F, 1965). The kind of sense organs found within the muscles and joints are called proprioceptors (Fox L. Edward).

Proprioception is an inner sense that works with the central nerves system. It is the ability of your brain to communicate and coordinate the movement of different parts of your body. It is your reflexes working to keep your body in balance. Good exercises to improve proprioception are those that challenge your balance and equilibrium. Proprioception works through proprioceptive nerve endings to sense your body's location. Muscle spindle fibers in the muscles communicate information to allow the muscles to maintain proper muscle tension to support the joints. Kinesthetic sense, or kinesthesia, is an outer sense that works with your body in space and time. It is your mind knowing where each part of your body is in relation to things around you. Good exercises to improve kinesthetic awareness are those that require coordination and movement control (Eric Borreson, 2013).

The function of proprioceptors is conduct sensory reports to the central nervous system from muscles, tendons, ligaments and joints. These sense organs are concerned with kinesthetic senses that, in general, unconsciously tell us where our body part in relation to our environment. Their contributions enable us to execute a smooth and coordinated movement (Fox L. Edward).

For a sports person it is extremely important to have information about what the muscles are doing and their position during a movement, it is also successfully argued that this muscles sense called kinesthetic sense and it is equally necessary for the successful execution of well learned skills. Kinesthetic is a keenly developed sense required of beginners and experts alike for

proficiency in many motor skills (Robert N. Singer, 1975). Life is full of competition as sports. Proper movement is required for daily fast life as well as in the sports competition. Cerebral and ganglia is responsible for motor learning which is very essential for normal life and in the field of all types of sports (Dr. Sarkar S, 2013).

To perform competency in hockey an individual must have good kinesthetic sense; or body awareness. An individual must be able to control the position of body, and to know where each body parts are at times. Kinesthetic awareness enables the child to jump, to turn quickly or slowly, to change the direction suddenly, and to perform any other movement necessary for the smooth execution of a skill. The integration of all four aspects of perception is required for complete perceptual development- development that required for participation in any hockey skill, whether cognitive or psychomotor. Coaches should be aware that perceptual development is continuous, and it is an essential part of performance at all level of skills. Adequate perception development allows athletes to use his or her physical abilities at the optimal level for highest possible level of performance (Jack H. Liewellyn et.al.1982)

Objectives of the Study:The objective of the study is to compare the kinesthetic perception of male and female hockey players.

Research Hypothesis: It is hypothesized that there would be no any significant difference in the kinesthetic perception between male and female hockey players.

Significance of the study: The result of the study may be of great help to the physical education teacher and coaches to classify the students in various groups for instruction purpose and to frame the training programmer accordingly.

Research Procedure

The procedure of this study consist of selection of subjects, selection of variables, criterion measures, testing procedure and the statistical technique employed for analysis of data.

Sample of the Study:For the purpose of this study fifteen male and fifteen female hockey players with the age range between 18 to 24 years were selected as subject by employing convenience sampling technique who represented Lakshmibai National Institute of Physical Education, Gwalior in Inter-University competition. The details are presented in the table1:-

Table 1

S. No.	Group	No. of Participants
1	Female Players	15
2	Male Players	15
Total Number of Participants		30

Criterion Measures: The scores of the subject on the kinesthetic obstacle test were used as the criterion measures for this study.

Administration of Test: In order to measure the kinesthetic perception of the subject the kinesthetic obstacles test was administered (Johnson, Barry L. & Nelson, Jackson k, 1988).

Purpose- The purpose of this test was to measure the ability of subject to predict the position during movement without the use of eyes.

Reliability- .53

Validity- Face Validity.

Age & Sex- Ten through college and satisfactory for both boys and girls.

Equipment- The test required material for building folding, chalk markers, twelve chairs and measuring tape.

Area- An area of 40×5 feet was marked on the floor and twelve chairs were arranged as obstacles in according with floor pattern as per the requirement as indicated in figure1.

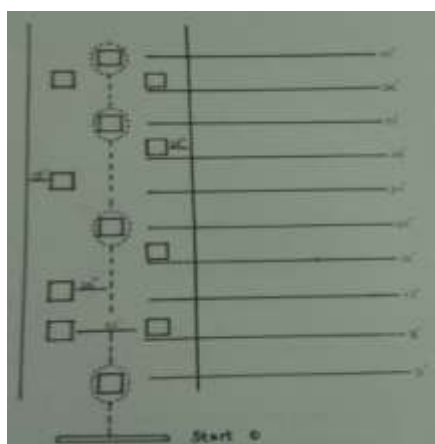

Figure 1. Marking of Kinesthetic Obstacle Test For the Test of Kinesthetic Perception.

Procedure- Each subject was allowed one practice trial of walking through the course without being blindfolded. The subject walked through the course with blindfolded for the test.

Scoring- The performer score 10 points for each stations he successfully clears without touching .There are 10 stations for maximum score of 100 points.

Penalty-

1. There was a 10 points penalty for each station he successfully cleared, without touching the obstacles.
2. There was a 10 points penalty for touching any part of the body against an object. After such penalty the subject was directed to the centre line and one step ahead of that particular station.
3. There was a 5 point penalty for each occurrence the subjects was directed back into the centre of line at the nearest point from which he went astray.

So the final score were recorded to present the kinesthetic perception of the subjects.

Statistical technique:

Statistical analysis was done with SPSS (Statistical Package for the Social Sciences, 20.0).Mean and standard deviation was calculated as a descriptive statistics and independent t-test was used to compare kinesthetic perception of male and female field hockey players. Then obtained “t” value was tested at 0.05level of significance. The assumptions for applying independent were also taken into consideration.

Results and Discussion of Findings: The result of independent t- test which was applied in order ascertains the difference between male and female hockey players on kinesthetic perception have been presented below:

Table 2: Descriptive Statistics on Kinesthetic Perception of Male and Female Field Hockey Players

Groups	N	Means	Std. Deviation	Std.error Mean
Female	15	61.33	11.09	2.86
Male	15	62.67	12.08	3.12

Table 1 shows the mean & standard deviation of hockey players on kinesthetic perception. In female hockey players group mean along with standard deviation 61.33 ± 11.09 similarly in male hockey players mean along standard deviation was 62.67 ± 12.08 . The mean score of Female and Male field hockey players are illustrated in Figure 2.

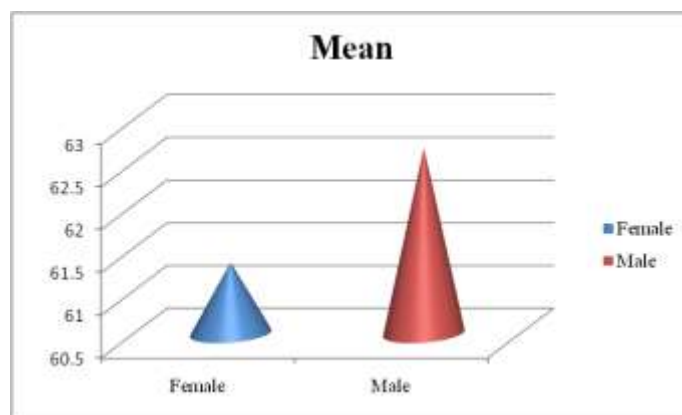

Figure: 2 Mean on Kinesthetic Perception of Male and Female Field Hockey Players.

Table 3: Independent t- test Statistics on Kinesthetic Perception of Male and Female Field Hockey Players

Groups	Means diff.	t-value	p-value	F-value	p-value
Female	-1.33	-.315	.76	.294	.59
Male					

Table 2 shows the mean difference, t-value and F-value to test the equality of variance (Levene's test was used). The mean difference on kinesthetic perception of male and female hockey players is -1.33. The F-value is .294 which is insignificant as the p-value is .59 which is more than .05 so, it is concluded that variance of both the groups are equal similarly the t-value is -.315 which is insignificant as the p-value is .76 which is more than .05 therefore it may be concluded that kinesthetic perception of Female and Male field hockey players are equal.

Conclusion

The present study was designed to compare the kinesthetic perception between male and female hockey players and Research findings provided the following information:

- 1) There was no significant difference between of male and female Inter-university hockey players on the kinesthetic perception.
- 2) The reason could be attributed to the fact that the dimension of the ground, height and weight of hockey stick, size of ball, the specificity of rules interpretation, techniques/ skill and system of formation of game are same for both the genders.
- 3) Another reason could be that both the group were undergoing a similar curriculum and had been adequate trained, so no difference were detected.
- 4) The other reason could be that apart from kinesthetic sense the visual and auditory senses play a very significant role in playing the game by both males and females.

Acknowledgement

The research scholar wishes to express her everlasting gratitude and respect to my guide Prof. Vivek Pandey H.O.D Exercise physiology, L.N.I.P.E, Gwalior (M.P) who was constant source of inspiration for his eradicate suggestion, enlightened guidance, constructive criticism, untiring help, critical supervision, noble guidance that served as a beckon light throughout the period of research work and was able to give this study its desired shape. The researcher also wish to give her heartily gratitude to all the female and male hockey players of L.N.I.P.E those were the part of the study for their interest collaboration and sincerity, without which this study would have been impossible.

Reference

- Singh R.M. (2000). *Comparative Study of Kinesthetic Perceptions of Male And Female Basketball Players* (Unpublished Master's thesis). Lakshmibai National University of Physical Education Gwalior. Page: 02
- Fernald F. (1965). *Introduction to Psychology* (5th Edition) Dubuque, Iowa: Wcb Publishers; Page: 137

- Fox L. Edward “*Physiological Basis of Physical Education and Athletics*” (4th Edition) Wm. C. Brown Publisher; Page: 143-144
- Eric Borreson (2013) “*Proprioception and Kinesthetic Sense*” Retrieved from <http://yangsheng.com/?p=9287> on 1/07/015.
- Robert N. Singer (1975) “*Motor Learning and Human Performance*” (2nd Edition) New York Mc. Millan Publishing Co. Inc; Page: 239
- Dr. Sarkar S (2013) “A Study on Relationship between Creative Motor Response and Kinesthetic Perception of Children” *International journal of innovative research & development* Vol. 2 Issue 9; Page: 129
- Jack H. Liewellyn and Judy A. Blocker (1982) *Psychology of Coaching: Theory and application* Delhi; Surjeet Publication; Page: 13
- Lephart S M, Kocher M S, Fu F H, Borsa P A, Harner C D. (1992) Proprioception following Anterior Cruciate Ligament Reconstruction” *J Sport Rehab*; Page: 188-96.
- Kamlesh, M.L. (2002) *Psychology in Physical Education and Sports* (4th Edition) New Delhi, Metropolitan Book Co. Pvt. Ltd.
- Johnson, Barry L. & Nelson, Jackson k. (1988) *Practical Measurements for Evaluation in Physical Education* (3rd Edition) Delhi; Surjeet Publication; Page: 343